

-  Smoke Alarm
-  Co2 Extinguisher
-  Dry Chem Extinguisher
-  Life Ring & Life Ring w/Light
-  First Aid Kit
-  Fuel Shut-off

DBL 78 FIRE PLAN

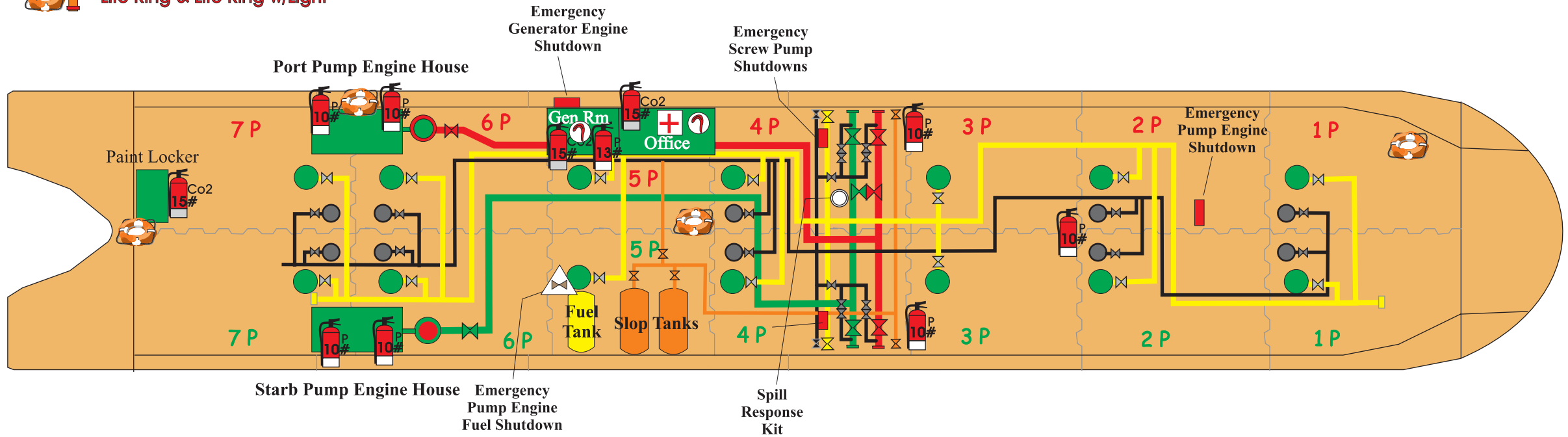

K-Sea Transportation Inc.

353.2' X 67' X 30'		CAPACITY - 73,024 BARRELS	
OPA 90 Double Hull Barge		1 PORT - 5,312.7	1 STARB - 5,361.29
YEAR BUILT : 2000		2 PORT - 6,146.78	2 STARB - 6,125.78
OFFICIAL No. 1102126		3 PORT - 5,248.43	3 STARB - 5,244.62
GROSS TONS: 5559 ITC		4 PORT - 6,117.28	4 STARB - 6,122.98
HULL Number Halter 302		5 PORT - 5,249.73	5 STARB - 5,259.64
PUMPS - Two Byron Jackson 12LS16GH		6 PORT - 6,096.83	6 STARB - 6,129.53
3 Stage Deepwell Pump (3300gpm)		7 PORT - 5,974.91	7 STARB - 5,942.12