

# DBL 53

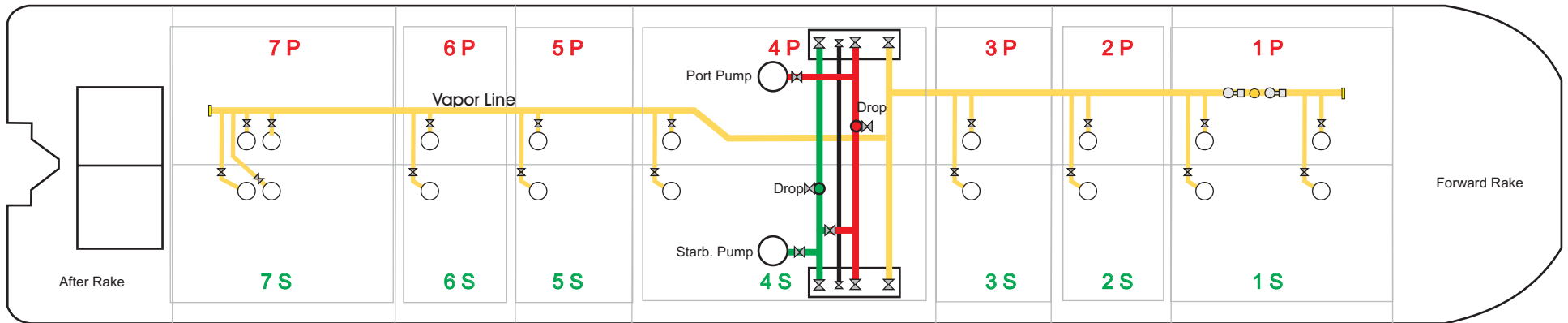

ABOVE DECK



340' X 68' X 22'  
 OPA 90 Double Hull Barge  
 YEAR BUILT : Dec. 1965  
 OFFICIAL No. 500121  
 GROSS TONS: 4543  
 HULL Number 232  
 IMO No. 1519400

**CAPACITY - BARRELS**

<b>1 PORT - 4876.911</b>	<b>1 STARB - 4948.706</b>
<b>2 PORT - 2258.439</b>	<b>2 STARB - 2292.102</b>
<b>3 PORT - 2661.415</b>	<b>3 STARB - 2659.230</b>
<b>4 PORT - 6311.200</b>	<b>4 STARB - 6283.368</b>
<b>5 PORT - 2649.978</b>	<b>5 STARB - 2692.530</b>
<b>6 PORT - 2268.592</b>	<b>6 STARB - 2272.806</b>
<b>7 PORT - 4927.734</b>	<b>7 STARB - 4947.892</b>

BELOW DECK

