









-  Smoke Alarm
-  Co2 Extinguisher
-  Dry Chem Extinguisher
-  150# B-V Dry Chemical Extinguisher
-  Life Ring & Life Ring w/Light
-  First Aid Kit
-  Survival Suit
-  Life Jacket
-  150# B-V Dry Chemical Extinguisher

DBL 32 FIRE PLAN

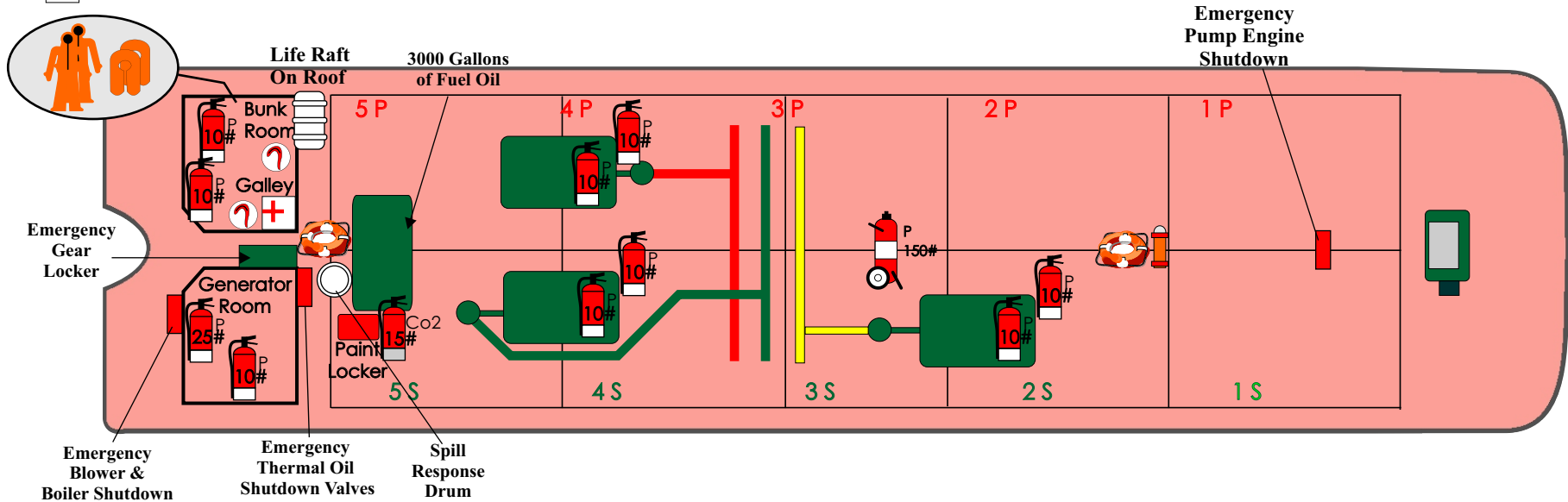

249.5' X 64' X 16'
Double Hull Barge
YEAR BUILT : 1999
OFFICIAL No. 1087118
GROSS TONS: 2146
PUMPS - 3 DEEPWELLS

CAPACITY - 33,252.53 BARRELS

1 PORT - 3877.88	1 STARB - 3883.32
2 PORT - 3887.38	2 STARB - 3883.86
3 PORT - 1666.39	3 STARB - 1660.59
4 PORT - 3311.06	4 STARB - 3313.93
5 PORT - 3388.16	5 STARB - 3879.96

Mattson
GRAPHICS

6/2013