

DBL 29

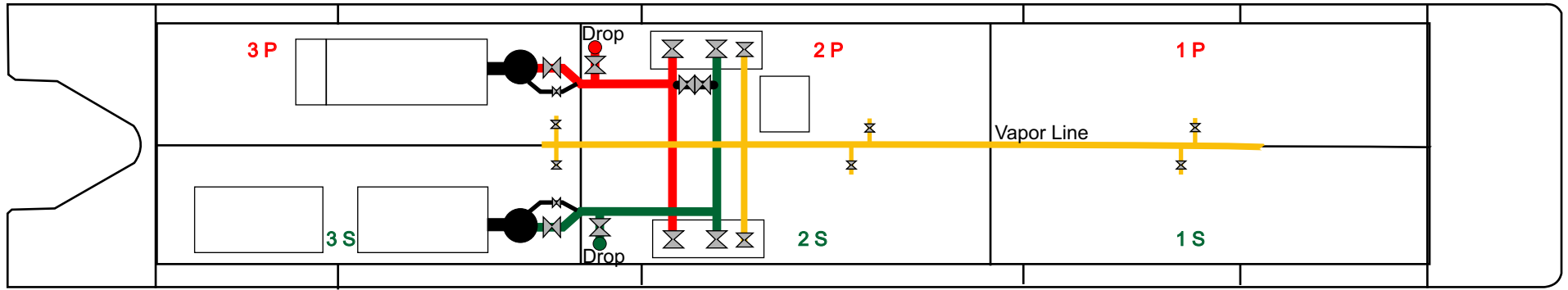

297'6" X 54' X 13'
Double Hull Barge
Year Built : 2006
Bollinger Hull 497
Official No. 1180995
IMO # 1588281
Gross Tons: 1754
Pumps - 2 Deepwells

CAPACITY - 28,000 BARRELS @100%

1 PORT - 4,850.4	1 STARB - 4,850.4
2 PORT - 4,486.2	2 STARB - 4,486.2
3 PORT - 4,697.1	3 STARB - 4,697.1

Loaded Draft 11.9'

